

## XSeries technical data and dimensions

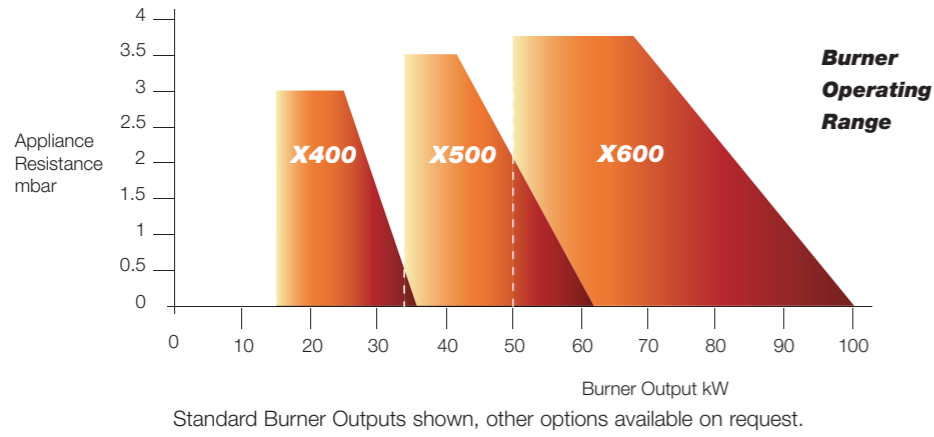

### Burner Dimensions (mm)

	AØ root	AØ max	B*	C	D	E	F	G	H	JØ	KØ	L
<b>X400</b>	89	89	80	231	50	161	194	138	297	90	125-150	10
<b>X500</b>	89	89	80	231	50	161	204	159	318	90	125-150	10
<b>X600</b>	89	89	80	231	50	161	204	169	360	90	125-150	10

\* Guidance only - other tube lengths are available.

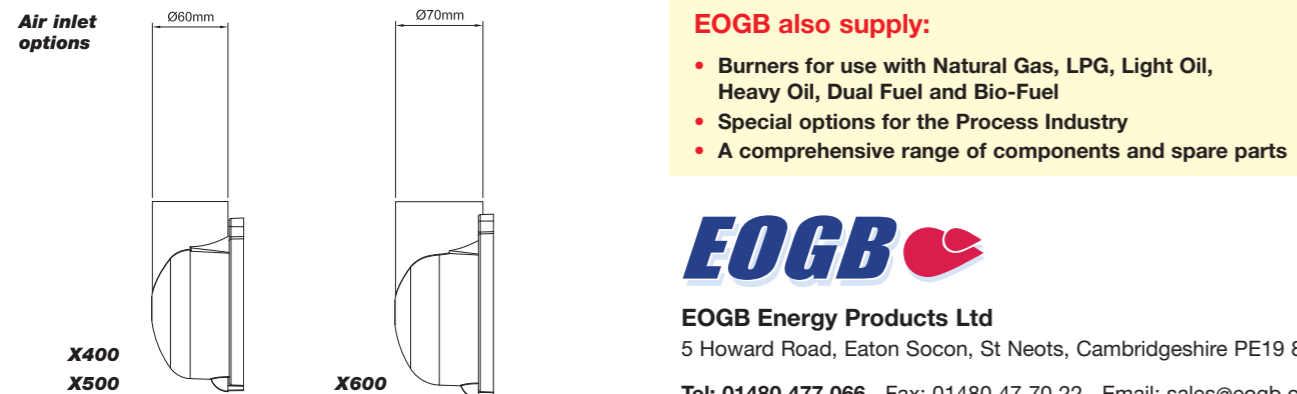
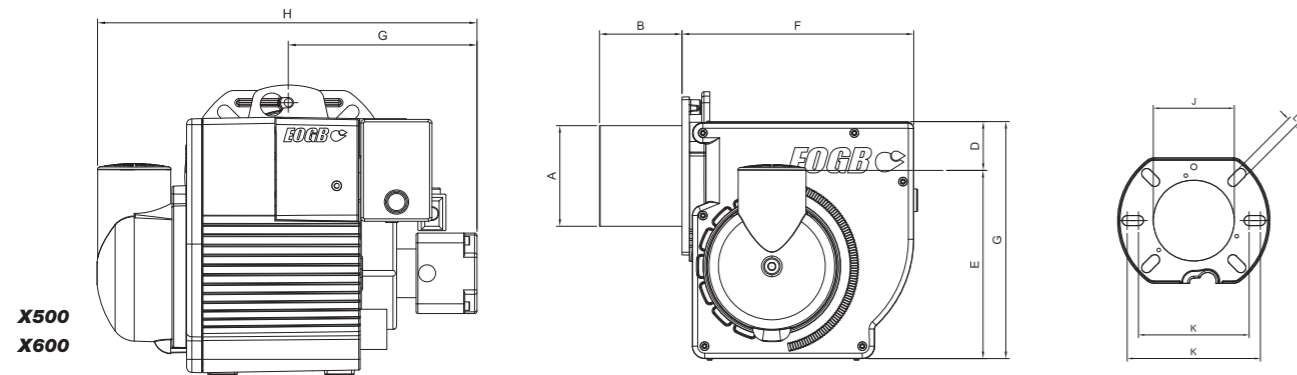
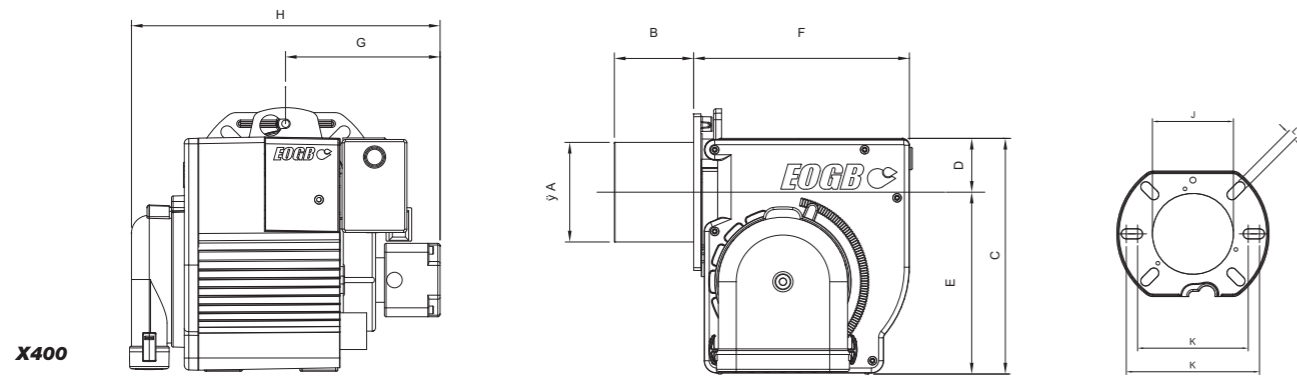

### EOGB also supply:

- Burners for use with Natural Gas, LPG, Light Oil, Heavy Oil, Dual Fuel and Bio-Fuel
- Special options for the Process Industry
- A comprehensive range of components and spare parts



**EOGB Energy Products Ltd**  
5 Howard Road, Eaton Socon, St Neots, Cambridgeshire PE19 8ET

Tel: 01480 477 066 Fax: 01480 47 70 22 Email: sales@eogb.co.uk  
www.eogb.co.uk

# XSeries Burners



EOGB Energy Products Ltd



reliable  
energy  
from EOGB

Innovative Features | Advanced Design | UK Manufactured | Enhanced Performance



EOGB Energy Products Ltd

# XSeries burners for domestic and light commercial heating

## X400 X500 X600



The **XSeries** oil burner range is the latest from EOGB, a company renowned for high quality, technical excellence and environmentally safe products.

Three models, with outputs ranging from 14-100kW, can be configured for conventional or ducted air inlets to suit installations in domestic, commercial and light industrial premises.



### Effort free installation & maintenance

The small compact **XSeries** burner fits most existing boilers; a universal mounting flange provides a solid airtight attachment and is secured by a single screw. Excellent access to all internal and external components without the need to break oil or electrical connections. For added engineer convenience, adjustment points for oil pressure, air and control box are all front facing and the whole control pack can be released by slackening the locking screws. The new **XSeries** offers simplicity and convenience and therefore reduces installation and maintenance costs.

### Meets stringent European environmental requirements

The **XSeries** has been designed to meet EN267 and also exceeds current European Standards for emissions. At EOGB the highest priority is given to developing environmentally safe products. As part of this philosophy, the simple and precise adjustment facilities of the **XSeries** encourage optimisation of performance for safe and economic operation.

### Supporting now, developing for the future

All EOGB personnel are long serving members of the oil firing industry with extensive knowledge of oil firing technology, supplying high quality products and services through boiler makers and specialist distributors around the UK and Ireland.

To meet new applications and changing requirements, EOGB operates a continuous development policy working with new technologies, users and environmental authorities in order to satisfy the demands of the future.

### Designed for the UK

The **XSeries** is built for the UK where there are significant differences in the oil fired burner market from other countries.

The predominant use of kerosene coupled with modern boiler designs which are generally cased, room sealed and have compact combustion chambers, place extra demands on the burner.

The range features:

- Superior performance
- Sophisticated construction materials
- Advanced design features
- Simple to service and maintain

### Built for today's markets

From concept to production every aspect of the **XSeries** and has been rigorously tested. Attention to detail has ensured reliable, continuous operation and compatibility with many of today's high resistance oil-fired boilers. Powerful motors with high temperature bearings are standard to give that extra life and reliability. Internationally recognised quality procedures are followed to monitor the highest standards of manufacture and performance.

Full technical product data online:  
[www.eogb.co.uk](http://www.eogb.co.uk)

### XSeries Burner Range

Three sizes from 14kW to 100kW

<b>X400</b>	<b>14 - 36 kW</b>
<b>X500</b>	<b>34 - 62 kW</b>
<b>X600</b>	<b>50 - 100 kW</b>



- The XSeries as standard is suitable for Bio-Diesel applications up to B10 Burners suitable for higher blends are available – ring for details
- Extensive range of Oil, Gas and Dual fuel burners from 14-4500kW ex stock
- Fast and reliable spares service
- Technical and training support
- Developing combustion solutions



Approved Training Centre

